



# SL-201 MK II

Dual Compressor / Limiter

**OWNER'S MANUAL**

**VESTAX CORP.**

2-37-1 Kamiyama, Setagaya-ku, Tokyo 154

Phone: 03-3412-7011 Fax: 03-3412-7013

**VESTAX MUSICAL ELECTRONICS CORP.**

2860 Cordelia Rd. Suite 120 Fairfield, CA 94585 U.S.A.

Phone: 707-427-1920 Fax: 707-427-2023

**VESTAX (Europe) Ltd.**

18 St. Christopher's Road, Haslemere, Surrey GU27 1DQ England

Phone: (0)1428-663117 Fax: (0)1428-661021

---

## <CONGRATULATIONS!>

Thank you for purchasing the VESTAX SL-201 MK2, Dual compressor/Limiter.

Please read this owner's manual carefully before you start to use your compressor, so that you will fully understand all of the special features and enjoy the full use of the product.

## [FEATURES]

The SL-201MK2 is a totally independent dual Compressor/Limiter with a stereo link function which allows stereo compression without losing its panning or dimensional effects.

Discrete circuitry creates the cleanest sound and the quickest response.

Back light analog VU meters are included for visual recognition. The meter action can be selected from the output level and the reduction level.

Totally independent controls for each channel with input level, attack time, release time, compression ratio and output level are provided for fine adjustment.

XLR balanced +4dB and 1/4 inch unbalanced -10dB jacks included for any application.

A dynamic microphone can be connected directly to the SL-201MK2 with perfect level matching.

## IMPORTANT

To prevent electric shock, do not remove cover. No user serviceable parts inside. Refer servicing to qualified personnel. Always disconnect all equipment from the main supply when disconnecting/reconnecting signal leads. The power cord should be connected last. Make sure that the power switch is off when connecting. Disconnect from AC supply when equipment is not used for an extended time.

## WARRANTY

Warranty might vary from country to country. Each distributor has their own warranty system in accordance with country or state regulations or laws. VESTAX observes the manufacturing country's regulations.

## PRECAUTIONS

### \*Humidity and dust

Avoid use where there is high humidity and dust which may cause damage to internal parts.

### \*Temperature

Avoid use in hot, (over 35) and cold, (below 5) locations. Keep the unit away from extreme direct heat such as direct sunlight, heating radiators, or closed vehicles.

### \*Power cord handling

Connecting the power cord to other cords or joining cords together can cause fire and electric shock. This is extremely dangerous. Take precaution when handling AC plugs and connectors.

Handle only the plug or connector and do not perform these operations with wet hands..

### \*Keep away from liquids

Do not stand vessel containing liquids on or near the equipment. If liquid enters equipment, disconnect the power cord from the power outlet immediately.

## SPECIFICATIONS:

<ul style="list-style-type: none"> <li>• INPUT LEVEL / IMPEDANCE</li> <li>MIC (UNBAL.) -46dB/3kΩ</li> <li>INST (UNBAL.) -28dB/150kΩ</li> <li>LINE (UNBAL.) -10dB/10kΩ</li> <li>MIC (BAL.) -46dB/3kΩ (hot 3)</li> <li>LINE (BAL.) 0dB/10kΩ (hot 3)</li> <li>• OUTPUT LEVEL / INPEDANCE</li> <li>LINE OUT (UNBAL.) -10dB/10kΩ 以上</li> <li>LINE OUT (BAL.) 0dB/600Ω 以上 (hot 3)</li> <li>• FREQUENCY RESPONSE 20Hz ~ 20kHz (±1dB)</li> <li>• S / N RATIO 74dB (FLAT)</li> <li>• COMPRESSION RATIO 3 : 1~20 : 1</li> <li>• ATTACK TIME 0.1mS ~ 10 mS</li> <li>• RELEASE TIME 0.1 sec ~ 1 sec</li> </ul>	<ul style="list-style-type: none"> <li>• THRESHOLD RANGE</li> <li>UNBALANCED</li> <li>MIC INPUT (INPUT VOL. MIN) ~ -65dB</li> <li>(INPUT VOL. MAX) ~ -41dB</li> <li>INST INPUT (INPUT VOL. MIN) ~ -42dB</li> <li>(INPUT VOL. MAX) ~ -18dB</li> <li>LINE INPUT (INPUT VOL. MIN) ~ -23dB</li> <li>(INPUT VOL. MAX) ~ +1dB</li> <li>BALANNCED</li> <li>MIC INPUT (INPUT VOL. MIN) ~ -65dB</li> <li>(INPUT VOL. MAX) ~ -41dB</li> <li>LINE INPUT (INPUT VOL. MIN) ~ -19dB</li> <li>(INPUT VOL. MAX) ~ +5dB</li> <li>• DIMENSIONS (w / h / d) 482 × 88 × 180mm</li> <li>• WEIGHT 4.2 Kg (2u)</li> </ul>
--	--

## CONTROL AND FUNCTIONS

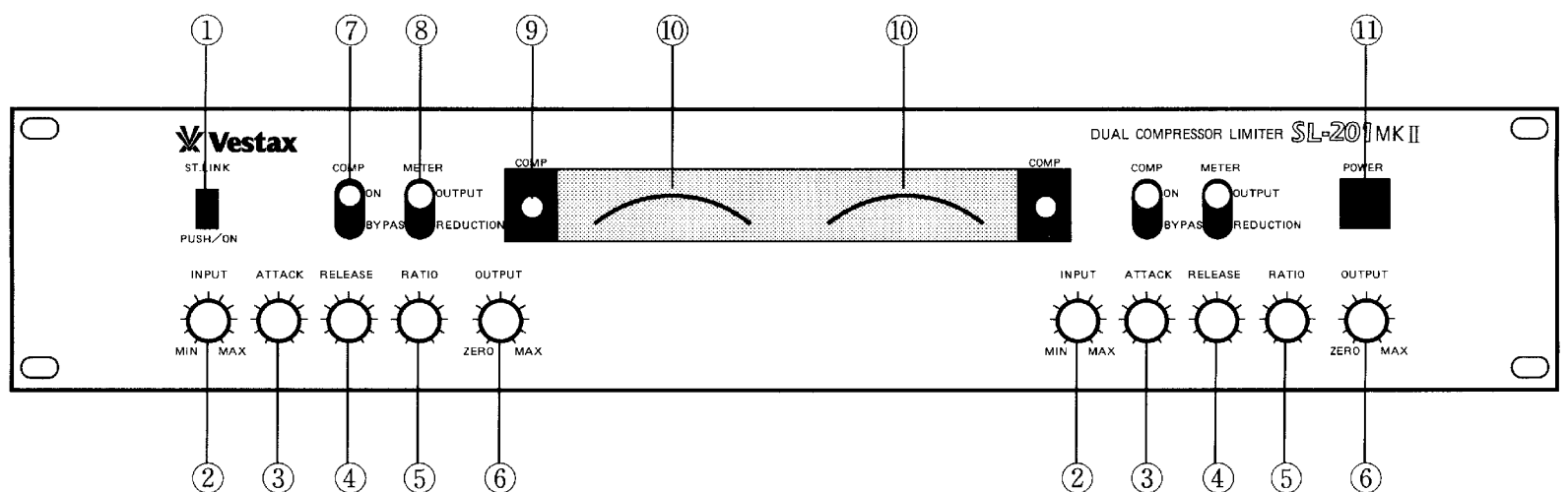

### FRONT PANEL

#### ① ST-LINK SWITCH

To combine channels 1 and 2, switch to STEREO. When the two channels are operating independently to create a stereo effect, a loud sound in one of the channels will activate the limiter, moving the sound image that should be balanced in the center to the other channel. This can be avoided by switching to STEREO. By combining the two channels, even when the limiter is activated by one side coming to the threshold point, equal amp gain can be maintained thus enabling balanced limiter effects on both sides of the stereo source. When the MODE switch is in STEREO, the channel that receives the high level signal first will become the "master", which the "slave" channel will then control the release. So it is important that the controls of both channels are set at equal levels.

#### ② INPUT VOLUME

Use for adjusting the input level. As threshold levels are fixed, when the input level is increased, input signals exceeded the threshold point are compressed.

#### ③ ATTACK

Controls the time from when the input signal passes above the threshold point to when the compression effect begins.

#### ④ RELEASE

The discrete circuit which compresses input signals above the threshold point also controls the signals passing below the point. This RELEASE control is used for clocking the return of the signals back to its original position.

\*Turning this control anti-clock-wise increases the speed of return.

\*Turning it clock-wise decreases the speed.

#### ⑤ RATIO

Controls the amount of compression exercised on the input signals. At 20 : 1, the effect of the limiter will be at its greatest. At this setting, there will be no increase in the already set output level regardless of input level increases above the threshold point.

#### ⑥ OUTPUT

Controls the output level of the compressed signals.

#### ⑦ COMP/BYPASS SWITCH

"COMP" activates the compressor/limiter effect. "BYPASS" in-activates the compressor/limiter, putting it into BYPASS mode.

#### ⑧ METER SELECT SWITCH

When the meter select switch - is output position, the VU meter shows output level. When the meter select switch is reduction position, the hand of VU meter moves to the 0dB position, and the VU meter indicates compressed level by the distance from its 0dB position. In case of a VU meter hand doesn't move when the switch lever turned to reduction position, increase the input volume since input level doesn't reach at the threshold level.

#### ⑨ COMP LED

When the LED is turning on, compressed input signal is outputting. Bypass signal is outputting when the LED is turning off.

⑩ VU METER ( left - channel 1, right - channel 2)  
The VU meter indicates output levels or compressed levels.

⑪ 11. POWER SWITCH: push sw ON/OFF

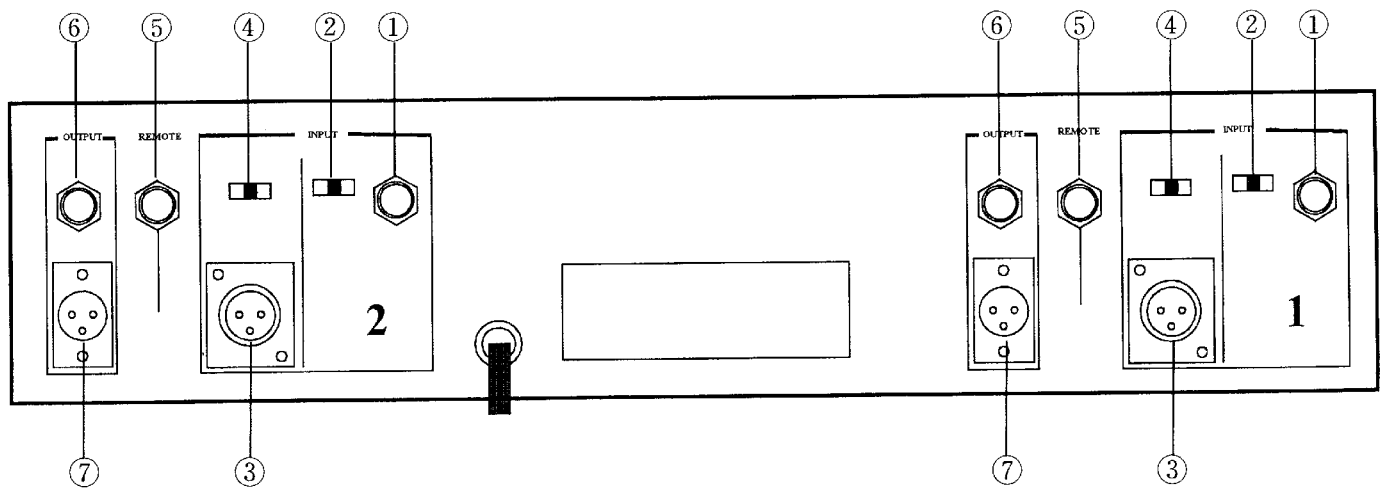

## REAR PANEL

- |   |  |
|---|--|
| <p>① UNBALANCED INPUT<br/>This is an unbalanced 1/4 inch phone jack input.</p> <p>② INPUT SELECTOR SWITCH (UNBALANCED INPUT)<br/>LINE – LINE level input (mixer, recorder)<br/>INST – INST level input (a musical instrument with pick up, guitar, bass ...)<br/>MIC – MIC level input (dynamic mic.)</p> <p>③ BALANCED INPUT (CANNON TYPE)<br/>Connect XLR-FEMALE plug, balanced input.</p> <p>④ INPUT SELECTOR SWITCH (BALANCED INPUT)<br/>LINE – LINE level input (mixer, recorder)<br/>MIC – MIC level input (dynamic mic.)</p> | <p>⑤ REMOTE<br/>It can be switching comp / bypass at foot switch (another sells)</p> <p>⑥ UNBALANCED OUTPUT JACK<br/>This is an unbalanced 1/4 inch phone jack output.</p> <p>⑦ BALANCED OUTPUT (CANNON TYPE)<br/>Connect XLR-MALE plug balanced output.</p> |
|---|--|

