

Professional Mixing Controller

PMC-20SL

OWNER'S MANUAL

SPECIFICATIONS

INPUT LEVEL/IMPEDANCE	TALK MIC	: -46dB/3.3K Ω
	PHONO 1, 2	: -42dB/56K Ω
	LINE 1~6	: -10dB/50K Ω
	EFFECT RTN	: -10dB/50K Ω
OUTPUT LEVEL/LOAD IMPEDANCE	OUTPUT 1, 2	: -10dB/10K Ω
	OUTPUT 1, HIGH	: 0 dB/10K Ω
	EFFECT SEND	: -10dB/10K Ω
	PHONE	: MAX 25mW/8 Ω
FREQUENCY RESPONSE	LINE~OUTPUT	: 20Hz~20kHz +0/-3 dB
	PHONO EQ	: RIAA \pm 1 dB
S/N RATIO	LINE~OUTPUT	: 90dB(IHF-A WTD)
T.H.D	MIC~OUTPUT	: 1kHz less than 0.03%
	LINE~OUTPUT	: 1kHz less than 0.03%
DIMENSIONS	: 482W \times 105H \times 220D mm (19" \times 4 1/4" \times 8 3/4")	
WEIGHT	: 4.5 kg	

— DIGITAL SAMPLER/DELAY SECTION —

AD/DA CONVERSION	: ADM
FREQUENCY RESPONSE	: 20Hz~18kHz (MULTI MIN)
S/N RATIO	: 75dB (IHF-A WTD)
SAMPLING TIME	: 2 SECOND (4BANK MODE)
	: 4 SECOND (2BANK MODE)
	: 8 SECOND (1BANK MODE)
DELAY TIME	: 128 ~512ms (SHORT)
	: 256 ~1024ms (MID)
	: 512 ~2048ms (LONG)



IMPORTANT

To prevent electric shock, do not remove cover.

No user servicable parts, refer servicing to qualified personnel.

Always disconnect all the equipment from the main supply when disconnecting the signal leads.

The power cord should be connected last. Make sure that the power switch is off when connecting.

Disconnect from AC supply when equipment is not used for an extended period of time.

PRECAUTIONS

Please read these instructions before operating this unit.

* Humidity and Dust

Avoid use where there is high humidity and dust which may cause damage to internal parts.

* Temperature

Avoid use in hot (over 35 °C/95° F) and cold (below 5°C/40° F) locations. Keep the unit away from extreme direct heat such as direct sunlight, heating radiators, or closed vehicles.

* POWER CORD HANDLING

Connecting the power cord to other cords or joining cords together can cause fire and electric shock. This is extremely dangerous.

Take precaution when handling AC plugs and connectors. Handle only the plug or connector and do not perform these operations with wet hands.

* KEEP AWAY FROM LIQUIDS

Do not stand vessels containing liquids on or near the equipment. If liquid does happen to enter equipment, disconnect the power cord from the power outlet immediately.

WARRANTY

Warranty might vary from country to country. Each distributor has their own warranty system in accordance with the country or state regulations. Vestax has manufacturers responsibility for products as determined by the manufacturing country's regulations.

CONGRATULATIONS!

YOU HAVE PURCHASED ONE OF THE FINEST DJ MIXERS AVAILABLE TODAY. IT HAS BEEN DESIGNED WITH PROFESSIONAL, WORKING DJ IN MIND.

CAUTION

CARE SHOULD BE TAKEN WHEN USING SHORT (25MM) CROSSFADERS. CONSTANT JARRING AGAINST THE END STOP WILL RESULT IN DAMAGE TO THE FADER AND MAY AFFECT WARRANTY. CROSSFADERS ARE USER-REPLACEABLE.

THE PMC 20SL MIXER contains all the features most requested by today's professional DJ. From the newly designed multiple mode digital looping sampler/digital delay, user replaceable crossfader, dual master outputs, selectable 5 band EQ assignable effects loop to the transformer switching and aural exciter you have every feature needed to give the DJ the maximum in special effects. But it doesn't stop there. Six line inputs, 2 phono inputs and a mic input allow the DJ all the program sources at the flick of a switch.

■ Built in Exciter

The PMC-20SL has a built in Exciter. This gives psycho-acoustic effects and enhances the sound by adding high harmonic elements to the original sound. Old records can thus have the sound quality of new records.

Exciter circuitry in the PMC-20SL is manufactured under license from Aphex Systems Ltd. It is basically the same as the Aphex Aural Exciter. Aphex Aural Exciter is a trademark of Aphex Systems Ltd.

■ Newly Developed Transformer Switch.

"Crossfader cancel system" makes transformer scratching quicker and easier. Furthermore, transformer scratching with the input selector switch is made easier by their panel positions. "Phono" is on the left side on PGM 2 and on the right side on PGM 3, so Transformer scratching can be achieved with same movements as the crossfader.

■ Detachable Crossfader

Vestax made the world's first detachable crossfader cartridge system. The PMC-20SL has the same system.

The PMC-20SL is factory fitted with a 45 mm stroke crossfader, (CF-20R). An optional 25mm stroke (CF-20S) is available and can be user fitted.

■ Dual Master Output Control

There are two output level controls both feeding separate jack outlets. These may be used for different sound zones. Also one pair may be used for recording.

A balance control is provided for each master output to enable balancing L/R speakers in the room.

■ Effect capability

Effect send switches are provided for each programme source so that effects can be processed individually. There are also effect send and effect receive (mix) level controls located in the master section for correct effect level setting to prevent signal overload and distortion.

■ Selectable meters

The LED Bargraph meters can be selected to indicate between output level, (Master 1 L/R) and input level (PGM 2&3). This enables you to check not only the output level but also to balance BPM by sight.

PART NAME & FUNCTION
FRONT PANEL

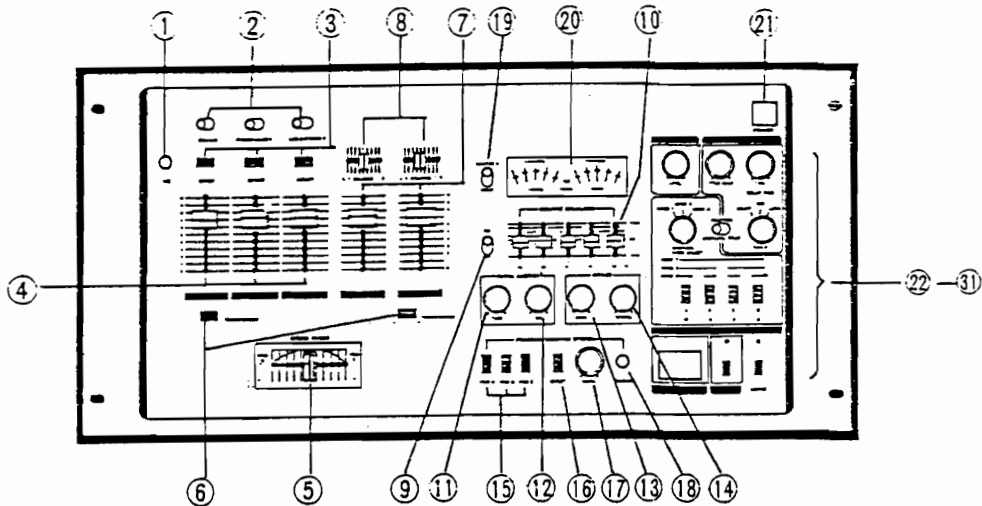

(1) Mic Input Jack (Standard .25 Inch Phone Jack).
Accepts a Dynamic microphone.

(2) Input select switches
Determines which input connectors are routed to fader, (4).

Programmes (PGM) are as follows:
PGM 1 Mic, Line 1, Line 2
PGM 2 Phono 1, Line 3, Line 4
PGM 3 Line 5, Line 6, Phono 2

Each input accepts the following signals

Mic : Dynamic Microphone

Line : CD Players, Cassette decks, Samplers etc with line level or -10dB output.

Phono : Turntable fitted with MM type cartridge. A preamp is required for MC type cartridges.

(3) EFFECT SWITCHES

Push to route signals through to either; built in effects or external effects processors connected to the send & return sockets. Pushing two or more buttons at the same time mixes signals together.

(4) INPUT FADER

Adjusts the level of each programme. Optimum sound quality will be obtained with the masters set so that input faders can be operated at between 7 and 8.

(5) CROSSFADER

When the input levels of PGM 2 and 3 are properly set, PGM 2 will be heard with the Crossfader set to the left side and PGM 3 will be heard with the Crossfader set to the right side. When the Crossfader is set in the centre, both programmes will be heard.

■ Replacement of Crossfader

If there is fader noise when fading between channels, or if the optional fader length is required, you may wish to change the fader. Please follow the instructions below.

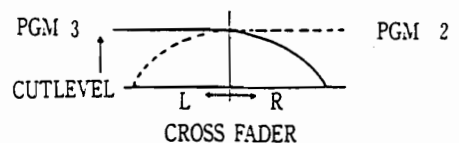

(A) Remove four screws which hold the crossfader unit.

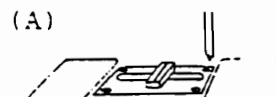

- (B) Carefully remove the multi-cable connector from the crossfader unit.

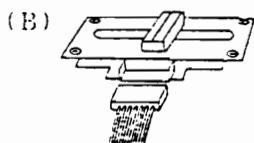

- (C) Insert the connector to the new crossfader unit and fix it to the main unit with four screws.

(6) TRANSFORMER SWITCH

There are two transformer switches. With the Crossfader set to the right and PGM 3 playing, depressing Transformer switch 2 will immediately change output to PGM 2 and vice versa. With these switches "Transformer Scratching" can be done very easily.

(7) MASTER FADER

Adjusts output level. Master 1 and Master 2 are parallel outputs. High level output is also adjusted by Master 1 fader.

(8) MASTER BALANCE

Determines balance of left and right channel of the same Master output.

(9) GRAPHIC EQUALISER ON/OFF SWITCH

In the down position the Graphic Equaliser will be by-passed.

In the up position the Graphic Equaliser will be operative.

(10) 5 BAND GRAPHIC EQUALISER

A Stereo 5 band graphic equaliser is provided for the output. It effects all outputs.

The frequency points are; 100Hz, 300Hz, 1KHz, 3KHz, and 10KHz.

(11) EXCITER FREQUENCY VOLUME

Adjusts effective frequencies by built in exciter circuitry.

Turning it counter-clockwise makes frequencies higher, turning it clockwise makes them lower.

(12) EXCITER MIX VOLUME

Adjusts mix of Exciter to dry (output) signal. Exciter effect is nothing at extreme counter-clockwise. Turning it clockwise increases effect.

(13) EFFECT SEND VOLUME

The send volume is used to adjust the signal sent to the built in digital delay and to the external effect equipment connected to the effect send jacks. This must be turned up in order for the digital delay to function.

(14) EFFECT RETURN VOLUME

Decides signal level from the external effect device returning to the PMC-20SL mixer.

(15) MONITOR SELECT AND SAMPLING SELECT SWITCH

When the built in digital circuitry is set to Sampler mode, this switch combines to work as the Sampling channel selector. Sampling level is automatically set. Note if this switch is not selected, Sampling will not be possible on that channel.

A programme monitor system is used in the PMC-20SL mixer. When stereo headphones are connected to the mixer, a mono mix of master 1 can be heard from the right. At the same time a mono mix of the selected programme can be heard on the left. This enables simultaneous listening of both input programme and output. The selected input programme can be heard regardless of the positions of faders or crossfader.

(16) EFFECT MONITOR SWITCH

Push to monitor signals from an external effects device connected to the send/return jacks.

(17) MONITOR LEVEL VOLUME

Adjusts headphone level.

(18) HEADPHONE JACK

For connection of monitor headphones.

(19) METER SELECT SWITCH

With this switch at "Master" 1 position the graph bar indicates Left and Right output channels separately.

At the "Input" position the left meter shows PGM 2 input and the Right meter shows the PGM 3 input.

(20) LEVEL METER AND POWER ON LED

(21) POWER SWITCH

- (B) Carefully remove the multi-cable connector from the crossfader unit.

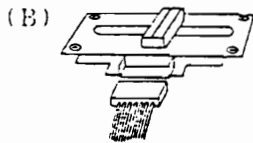

- (C) Insert the connector to the new crossfader unit and fix it to the main unit with four screws.

(6) TRANSFORMER SWITCH

There are two transformer switches. With the Crossfader set to the right and PGM 3 playing, depressing Transformer switch 2 will immediately change output to PGM 2 and vice versa. With these switches "Transformer Scratching" can be done very easily.

(7) MASTER FADER

Adjusts output level. Master 1 and Master 2 are parallel outputs. High level output is also adjusted by Master 1 fader.

(8) MASTER BALANCE

Determines balance of left and right channel of the same Master output.

(9) GRAPHIC EQUALISER ON/OFF SWITCH

In the down position the Graphic Equaliser will be by-passed.

In the up position the Graphic Equaliser will be operative.

(10) 5 BAND GRAPHIC EQUALISER

A Stereo 5 band graphic equaliser is provided for the output. It effects all outputs.

The frequency points are; 100Hz, 300Hz, 1KHz, 3KHz, and 10KHz.

(11) EXCITER FREQUENCY VOLUME

Adjusts effective frequencies by built in exciter circuitry.

Turning it counter-clockwise makes frequencies higher, turning it clockwise makes them lower.

(12) EXCITER MIX VOLUME

Adjusts mix of Exciter to dry (output) signal. Exciter effect is nothing at extreme counter-clockwise. Turning it clockwise increases effect.

(13) EFFECT SEND VOLUME

The send volume is used to adjust the signal sent to the built in digital delay and to the external effect equipment connected to the effect send jacks. This must be turned up in order for the digital delay to function.

(14) EFFECT RETURN VOLUME

Decides signal level from the external effect device returning to the PMC-20SL mixer.

(15) MONITOR SELECT AND SAMPLING SELECT SWITCH

When the built in digital circuitry is set to Sampler mode, this switch combines to work as the Sampling channel selector. Sampling level is automatically set. Note if this switch is not selected, Sampling will not be possible on that channel.

A programme monitor system is used in the PMC-20SL mixer. When stereo headphones are connected to the mixer, a mono mix of master 1 can be heard from the right. At the same time a mono mix of the selected programme can be heard on the left. This enables simultaneous listening of both input programme and output. The selected input programme can be heard regardless of the positions of faders or crossfader.

(16) EFFECT MONITOR SWITCH

Push to monitor signals from an external effects device connected to the send/return jacks.

(17) MONITOR LEVEL VOLUME

Adjusts headphone level.

(18) HEADPHONE JACK

For connection of monitor headphones.

(19) METER SELECT SWITCH

With this switch at "Master" 1 position the graph bar indicates Left and Right output channels separately.

At the "Input" position the left meter shows PGM 2 input and the Right meter shows the PGM 3 input.

(20) LEVEL METER AND POWER ON LED

(21) POWER SWITCH

(22) MIX—LEVEL

This control varies the level of built in Delay and Sampler Playback volume.

(23) FEEDBACK

When the function switch is set to "Delay", this control determines the number of repeats. One repeat will be obtained with the control set to the left. (Note this is automatically cancelled when Sampling is selected.)

(24) FINE

This control varies both the sampling time and Delay time for playback, as well as sample record.

(25) RANGE

Sets range of adjustment for delay time,

- Short 128 - 512 ms
- Mid 256 - 1024 ms
- Long 512 - 2048 ms

(Note, this is automatically cancelled when sampling is selected.)

(26) FUNCTION SWITCH

Selects Digital Delay or Digital Sampler FUNCTION.

(27) SAMPLING MODE SELECTOR

Selects range of adjustment for sampling time.

- Mode 1 1 bank maximum Sampling time 8 seconds
- Mode 2 2 banks maximum Sampling time 4 seconds each
- Mode 3 4 banks maximum Sampling time 2 seconds each

(28) BANK SWITCHES A B C D / BANK INDICATOR LED

Selects Sampling banks. An indicator LED shows selection.

- Mode 1 1 bank, use bank A (8 seconds)
- Mode 2 2 banks, use banks A & C (2x4 seconds)
- Mode 3 4 banks, use banks A, B, C & D (4x2 seconds)

(29) PLAY SWITCH

In Sampling mode this switch starts and re-starts playback of the Sampled sound. Playback automatically stops when the Sampled sound comes an end.

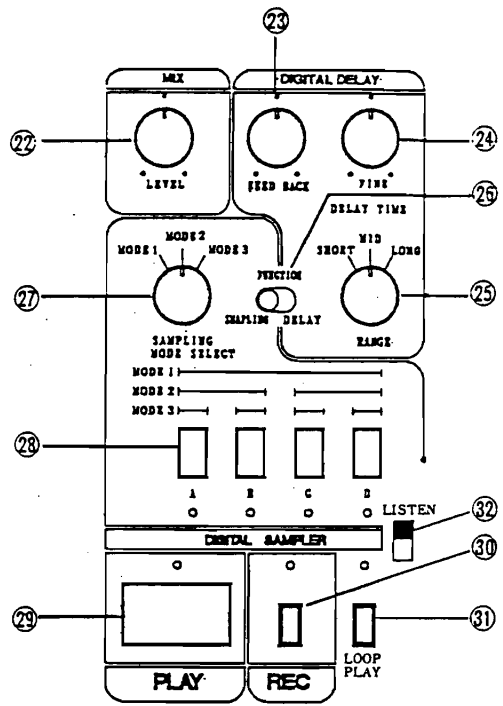

(30) RECORD SWITCH

In sampling mode this switch initiates Sampling, (recording). The red LED indicates the PMC-20SL is in the record mode. Sampling will automatically stop when the selected time ends. (As set by the sampling mode selector and the Fine control.)

(31) LOOP PLAY SW. INDICATOR

When this switch is pressed the sampled sound which has been recorded is played back repeatedly. The indicator of the bank selected for playing flashes to show in which bank the sound is recorded.

Also, when in mode 1 and 2, it indicates the order of play back, and can therefore be used as a basis for timing of sampling. Push again to release from loop play.

(32) LISTEN

Push to monitor Sampler playback and Delay signal. The monitor signal can be heard at all times regardless of the positions of mix volume and faders.

REAR PANEL

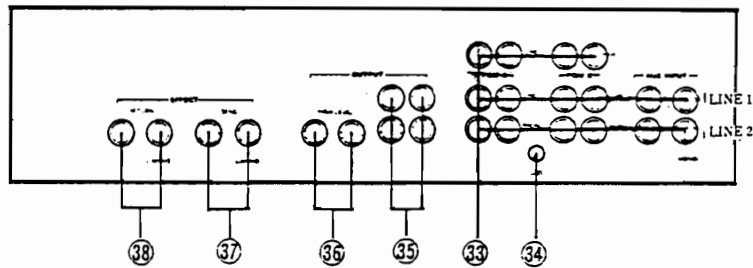

(33) INPUT JACKS FOR PGM 1 LINE 1, 2 INPUT
(RCA phono jack)
-10dB line level inputs for CD player, cassette deck and Digital Sampler.

(34) INPUT JACKS FOR PGM 2 & 3
Line 3 through 6 (L/R). Phono 1 & 2 (L/R) (RCA phono jacks).
Connect CD player, Cassette deck, etc to line inputs. Connect Turntables with MM cartridges to phono inputs.

(35) GROUND TERMINAL
Connect the earth cord from turntables.

(36) OUTPUT JACK 1 & 2 (L/R). (RCA phono).
-10dB output jacks for connection to pre-amps, power amps, recorders etc.

(37) OUTPUT JACK 1 (HIGH LEVELS) L/R
(standard phone jack).
0dB boosted output jacks from Master 1.

(38) EFFECT SEND JACK L/R, (Standard Phone Jacks).
Signal for input of external effects devices, when a mono signal is used connect it to the L (mono) jack.

(39) EFFECT RETURN JACK L/R, (Standard phone Jack).
Accepts signals from external effects devices. When a mono signal is used connect it to the L (mono) Jack.

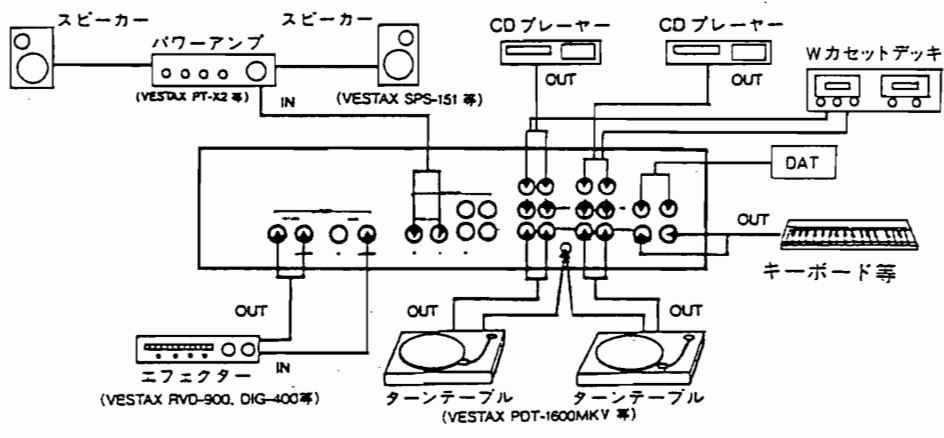

NOTES ON SAMPLING FUNCTION OF PMC-15SL/20SL PMC-15SL/20SL のサンプラー機能についての注意

The MONITOR (LISTEN) switch is located on the Sampler Section of the PMC-15SL/20SL. This allows monitoring of the Sampler through the headphones. When this switch is ON, the output of the Sampler can be heard through the LEFT channel of the headphones. At that time, please note that the sound selected by CUE SELECT (MONITOR SELECT) switch cannot be heard.

本機のサンプラー部には、サンプラー/ダイレイの再生音をヘッドホンでモニターするための MONITOR (LISTEN) スイッチが搭載されています。このスイッチがオンのときに、ヘッドホンの L チャンネルでサンプラー/ダイレイの再生音をモニターできますが、CUE SELECT (MONITOR SELECT) スイッチによって選択されている音は聞こえなくなりますので、ご注意下さい。

VESTAX CORPORATION

PMC-15SL/20SL 1995