



Professional Mixing Controller

PMC 17A

OWNER'S MANUAL

VESTAX CORP.

2-37-1 Kamiyama, Setagaya-ku, Tokyo 154

Phone: 03-3412-7011 Fax: 03-3412-7013

VESTAX MUSICAL ELECTRONICS CORP.

2860 Cordelia Rd. Suite 120 Fairfield, CA 94585 U.S.A.

Phone: 707-427-1920 Fax: 707-427-2023

VESTAX (Europe) Ltd.

18 St. Christopher's Road, Haslemere, Surrey GU27 1DQ England

Phone: (0) 1428-653117 Fax: (0) 1428-661021

CONGRATULATIONS!

Thank you for purchasing the VESTAX PMC-17A, Professional Mixing Controller. The top of the line, the PMC-17A is a high specification mixer designed to meet the most professional requirements of the Dance Music DJ's today.

Please read this owner's manual carefully before you start to use your mixer, so that you will fully understand all of the special features and enjoy the full use of the product.

FEATURES

- 1 phono, 2 line inputs are provided to each program. 1 phono, 1 line and 1 mic input are provided to the sub input channel for more mixing capability. Each input channel has a trim control for the setting of input levels. A balance control and three band EQ are also provided on each channel. The separate Mic input section has its own EQ.

The 60 m/m long fader is provided for fine level mixing, so that the PMC-17A is perfect for TECHNO, TRANS, HOUSE MUSIC and JUNGLE, for the demands of long mixing.

- The mic channel permits level control for MIC1, MIC2 and MIC3 also it adjusts the low pass and high pass filter with the 2 band equalizer.
- The PMC-17A has an effect send switch for each channel. It allows for a variety of effects such as digital delay or a multi-effect with 2-in and 2-out stereo/
- send/return.

The newly designed cross fader and input fader, based on field studies and past experience, is specially "curved" and has the durability to endure hard scratching. Maintenance is easy with the user

- replaceable cross fader and input fader.

The Input fader of each program channel is a detachable format so that it can be replaced with an optical rotary Fader unit. Then the PMC-17A becomes a US HOUSE MUSIC style DJ mixer.

IMPORTANT

To prevent electric shock, do not remove the cover. No user serviceable parts are inside. Please refer servicing to a VESTAX Authorised Service Center. Always disconnect all equipment from the main supply when disconnecting or reconnecting signal leads. The power cord should be connected last. Make sure that the power switch is off when connecting. Disconnect from AC supply when equipment is not used for extended amount of time.

WARRANTY

The warranty might vary from country to country. Each distributor has their own warranty system in accordance with the country or state regulations or laws. VESTAX observes the manufacturing country's regulations.

PRECAUTIONS

*Humidity and dust

Avoid use where there is high humidity and dust which may cause damage to internal parts.

*Temperature

Avoid use in hot, (over 35°C) and cold, (below 5°C) locations. Keep the unit away from extreme direct heat such as direct sunlight, heating radiators, or closed vehicles.

*Power cord handling

Connecting the power cord to other cords or joining cords together can cause fire and electric shock. This is extremely dangerous.

Take precaution when handling AC plugs and connectors. Handle only the plug or connector and do not perform these operations with wet hands.

*Keep away from liquids

Do not stand cans containing liquids on or near the equipment. If liquid enters equipment, disconnect the power cord from the power outlet immediately.

CONTROL AND FUNCTIONS

TOP PANEL

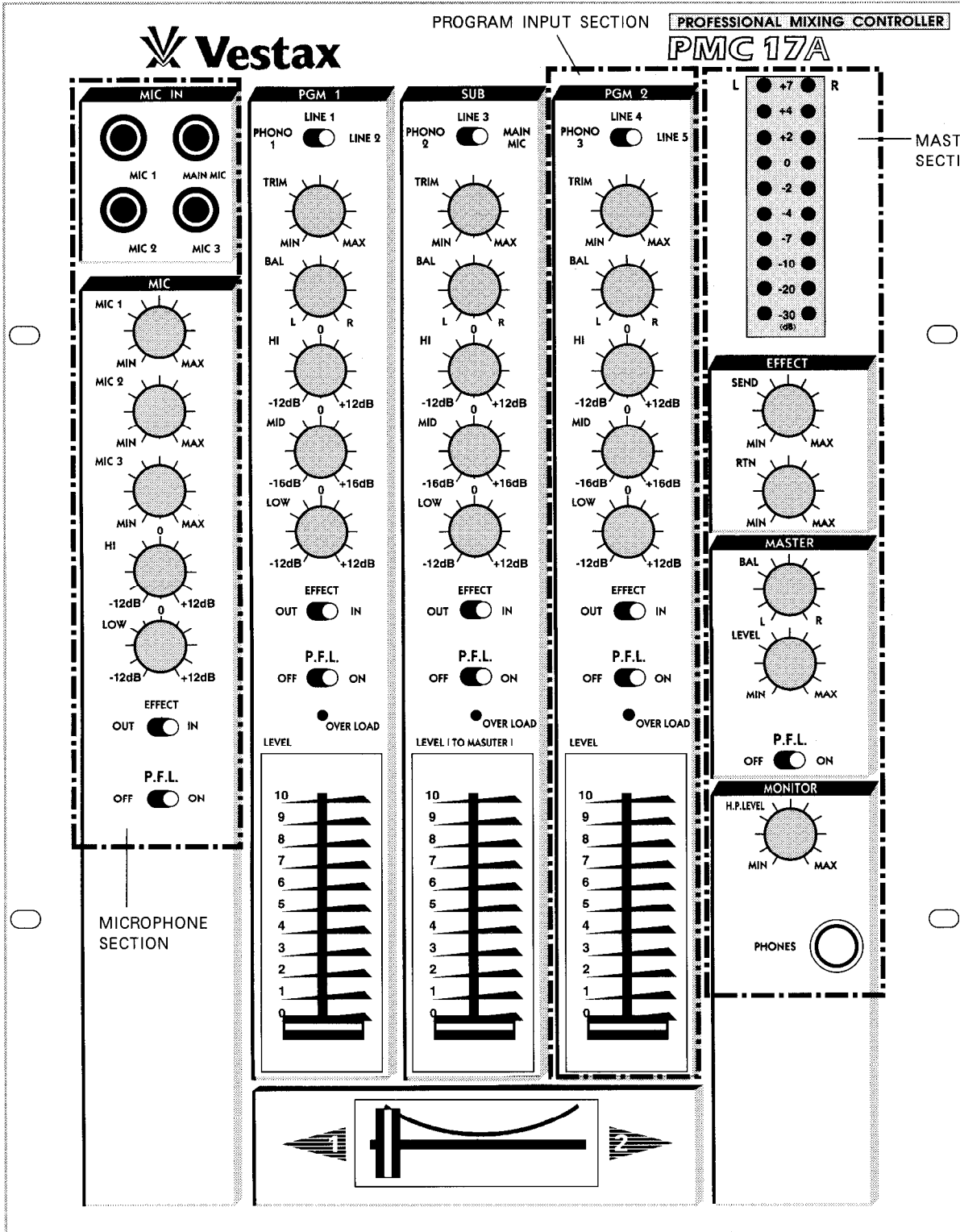

PROGRAM INPUT SECTION

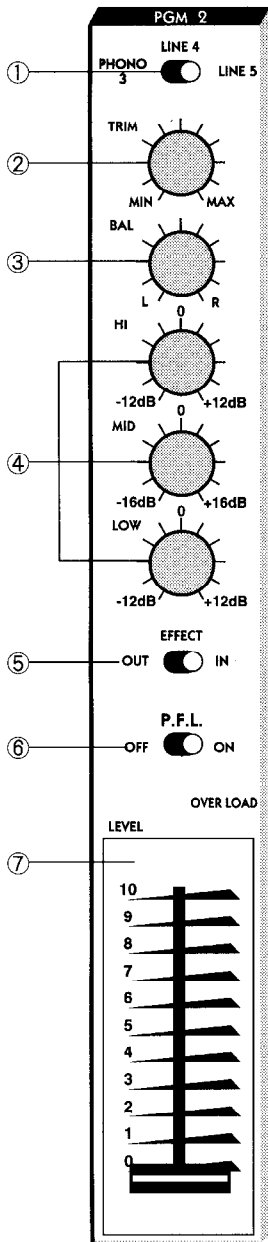

PROGRAM INPUT SECTION

1. INPUT SELECTOR

Used to select the input (two LINE or one PHONO) to be sent to each PGM channel.

2. TRIM CONTROL

Adjusts the input level of each channel. Set INPUT FADER to 7-8 position, adjust TRIM so that the INPUT LEVEL METER shows about 0 dB.

3. BALANCE CONTROL

Adjusts the stereo balance for each PGM channel. Can be used for adjusting the unbalanced stereo image caused by a strong Anti-Skating setting. Clockwise rotation from center position increases the volume of R over L channel. A counter clockwise rotation increases the volume of L channel over R.

4. EQ (HI, MID, LOW)

Adjusts the HI, MID and LOW frequencies for each PGM channel. Each band has following specifications.

HI	8kHz	±12dB	Shelving type
MID	500Hz	±16dB	Peaking type
LOW	80Hz	±12dB	Shelving type

5. EFFECT SWITCH

Used when sending signal to a external effect processor connected to EFFECT SEND/RETURN.

6. P.F.L SWITCH (PRE FADER LISTEN SWITCH)

Used to send the signal from each program to the monitor section for headphone monitoring.

7. INPUT FADER

Used to adjust the input level of each program. Usually set at the 7-8 position.

This is a detachable fader for the ease of replacement. Replace with IF-R when it is worn out.

How to replace the input fader:

- Remove four screws which hold the fader unit panel.
- Take the unit out with the panel.
- Carefully remove the multi-cable connector from the fader unit.
- Insert the connector to the new fader unit.
- Replace the fader unit panel and tighten the screws.

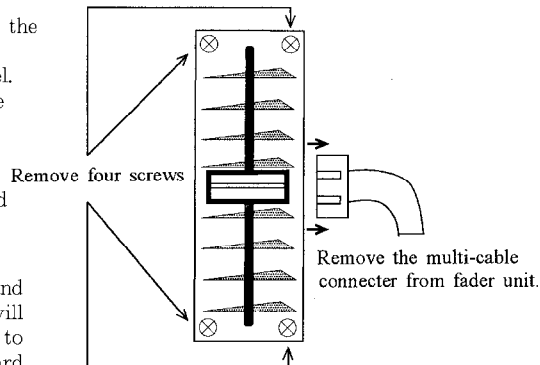

8. CROSSFADER

When the input level of PGM1 and PGM2 are properly set, PGM1 will be heard with the cross fader set to the left side. PGM2 will be heard with the cross fader set to the right side. When the cross fader is set in the center, both programs will be heard. This is a detachable fader for the ease of replacement with CF-R when it is worn out.

How to replace the fader:

- Remove a knob and four screws which hold the fader unit.
- Take the unit out.
- Carefully remove the multi-cable connector from the fader unit.
- Insert the connector to the new fader unit.
- Replace the fader unit and tighten the screws.

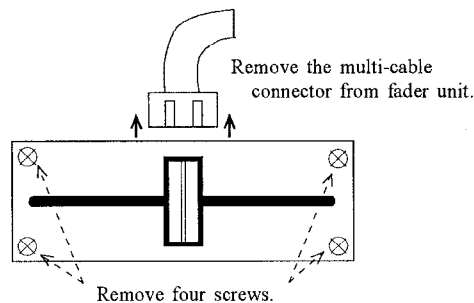

MICROPHONE SECTION

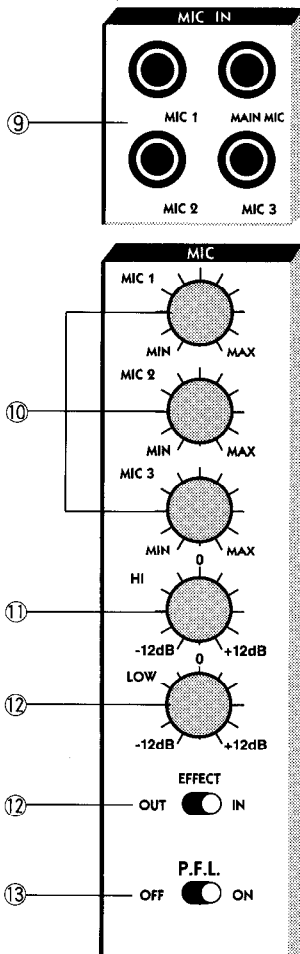

MICROPHONE SECTION

9. MIC INPUT JACK (MIC 1, 2, 3, MAIN MIC)
Input jacks of MIC1, 2, 3, MAIN MIC. Be careful so that the MAIN MIC input is switched to the sub input channel.
10. MIC LEVEL
Adjusts the input level from all microphone inputs.
11. MIC EQ (HI, LOW)
Adjusts the HI and LOW frequencies for all the microphone input.
12. EFFECT SWITCH
Used when sending signal to the external effect processor connected to the EFFECT SEND/RETURN
13. P.F.L SWITCH (MICROPHONE SECTION)
Used to send the signal from the mic channel to the monitor section for headphone monitoring.

MASTER SECTION

14. MASTER OUT LEVEL METER
The LED level meters indicate the signal level of the LINE OUT.
15. EFFECT SEND LEVEL
Used to adjust send the level from the EFFECT SEND. The signal is selected by the EFFECT SWITCH (5).
16. EFFECT RETURN LEVEL
Used to adjust the return level to the EFFECT RETURN. This EFFECT RETURN can be used as the sub line input.
17. MASTER BALANCE VOLUME
Adjusts the signal balance of the left to the right side of the outputs from the LINE OUT jack on the rear panel.
18. MASTER LEVEL VOLUME
Adjusts the signal level output from the LINE OUT jack on the rear panel.
19. P.F.L SWITCH (MASTER SECTION)
Used to send the signal from the LINE OUT jack on the rear panel to the monitor section for headphone monitoring.
20. HEADPHONE LEVEL
Adjusts the headphone output level.
21. HEADPHONE JACK
Use this jack to connect the headphones. Headphones from 8 ohm to 600 ohm can be used. 150 ohm is recommended

MASTER SECTION

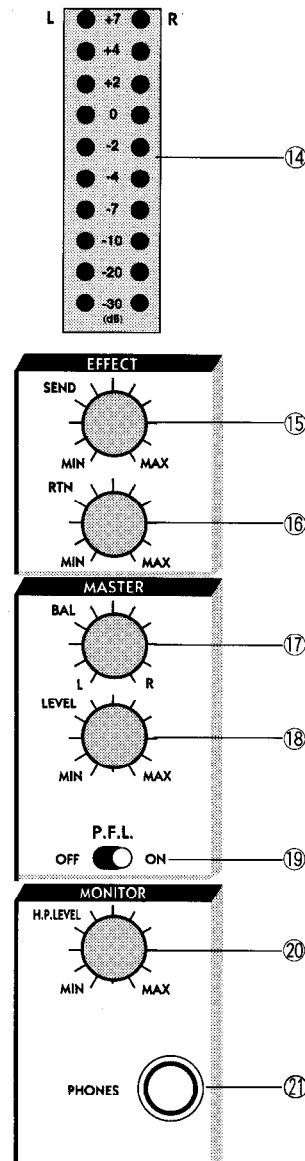

REAR PANEL

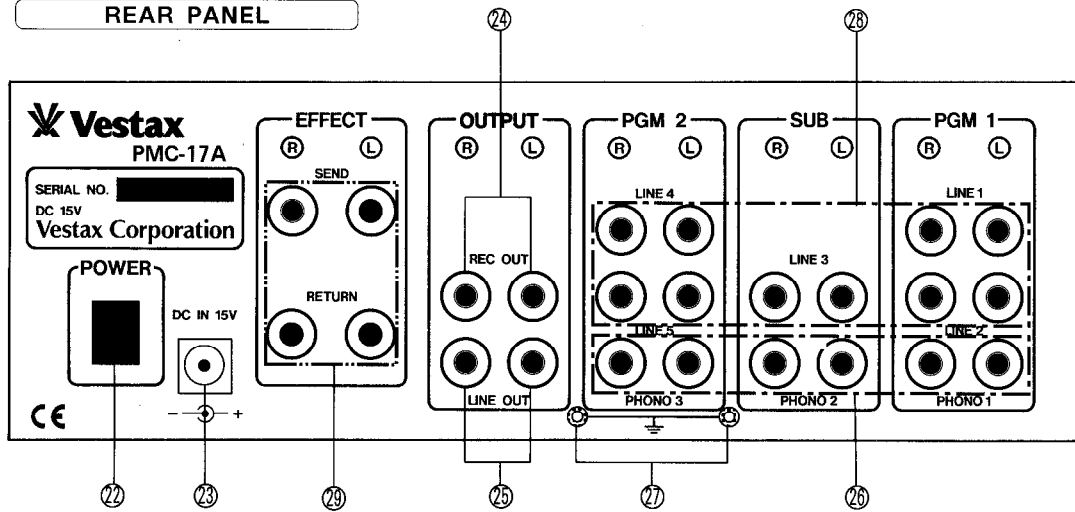

22. POWER SWITCH

The first LED of the MASTER OUT LEVEL METER that is located on the top panel is lit when on.

23. DC IN

Connect to the DC-15 AC adapter.

24. REC OUT

Output for recording. Connect to the input jack of the tape deck. You can also use the sub output when you need to have an output besides the main output.

Pre-fader constant level output. MASTER LEVEL VOLUME does not effect the level.

25. LINE OUT

Connect to the input of a power amplifier.

26. PHONO INPUT

Input jack for PGM1, PGM2 and SUBcH turntables. Connect turntables equipped with the MM pickup cartridges only.

27. GND TERMINAL

Connect this terminal to the ground lead of the turntable. This helps to reduce noise and hum.

28. LINE INPUT

Input connectors for line level equipment such as CD players, tape decks, DATs, MDs etc..

29. EFFECT SEND/RETURN

Connect the SEND jacks to the input of an external effector unit. (Delay, Reverb etc.) Connect the RECEIVE jacks to the output of the effector. STEREO IN/STEREO OUT effectors or MONO IN/MONO OUT effectors both can be used. When MONO is connected use L terminals.

SPECIFICATIONS

● Nominal Input Level/Impedance	
PHONO	-42dBV/47k Ω
LINE	-10dBV/47k Ω
MIC	-42dBV/3.3k Ω
AUX RTN	-10dBV/47k Ω
● Nominal Output Level/Impedance-	
LINE OUT	-4dBV/10k Ω
REC OUT(BAL)	-10dB/10k Ω
AUX RTN	-10dB/10k Ω

● Frequency Response	20Hz - 20kHz (+0, -3dB)
● S/N Rati	≥ 80 dB
● Dimensions (W×H×D)	270×80×353mm