

CONGRATULATIONS!

Thank you for purchasing Vestax's PMC-280.
 There has been a change in the "HOW TO CANGE THE FADER UNIT" section in page 25.
 Please read this supplemental instruction sheet to operate the PMC-280 safely and to enjoy its full spec.

■ HOW TO CHANGE THE FADER UNIT

- ① Remove the screws on the fader panel.
(see fig.B)
- ② Remove the fader unit from the mixer.
- ③ Carefully remove the multi-cable connector from fader unit.
(see fig.C)
- ④ Attach multi-cable connector to new fader unit.
- ⑤ Position the fader unit carefully and secure with screws.

※ HOW TO REPLACE THE CF UNIT WITH "CF-PCV"

Please see fig.C for replacement of the fader. Place the fader unit in the proper position and fix it with two screws. (fig.D-b)
 There is a switch for CF-PCV unit. When "CF-PCV" unit is installed, set the switch to "PCV" mode.

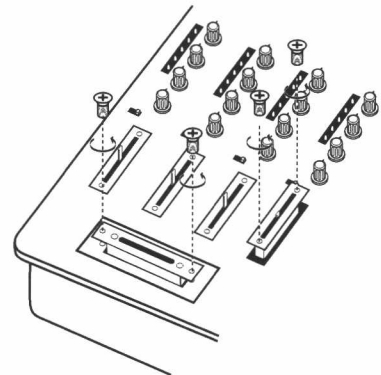

fig.B

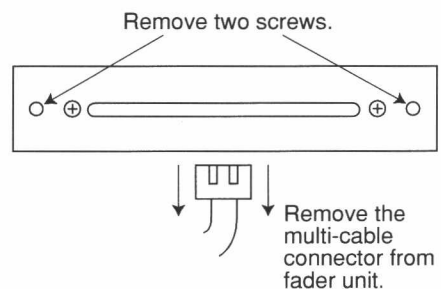

fig.C

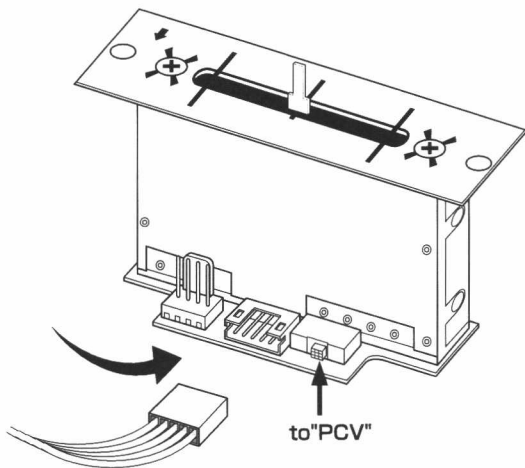

fig.E

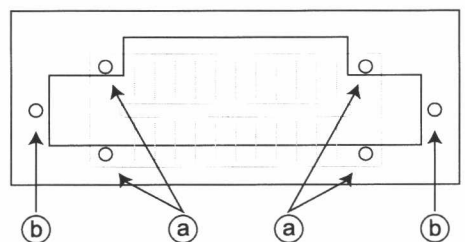

fig.D

- Ⓐ: CF-RUS or CF-R
- Ⓑ: CF-PCV