



3 BAND ISOLATER

DCR-1200

OWNER'S MANUAL

VESTAX CORP.

2-37-1 Kamiyama, Setagaya-ku, Tokyo 154 Japan

Phone: 03-3412-7011 Fax: 03-3412-7013

VESTAX MUSICAL ELECTRONICS CORP.

2860 Cordelia Rd., Suite 120 Fairfield, CA 94585 U.S.A.

Phone: 707-427-1920 Fax: 707-427-2023

VESTAX (Europe) Ltd.

18 St. Christophers Road, Haslemere, Surrey GU 27 1DQ England.

Phone: (0)1428-653117 Fax: (0)1428-661021

CONGRATULATIONS!

Thank you for purchasing the VESTAX DCR-1200, 3 BAND ISOLATOR. Please read this owner's manual carefully before you start to use, so that you will fully understand all of the special features and enjoy the full use of the product.

FEATURES

- DCR-1200 can be used to divide music source into 3 band HI,MID,LOW frequency, for the creative professional DJ.
- DCR-1200 can cancel the center point of the music source by use of the "INVERTMIX".
- DCR-1200 has large aluminum knob to increase the erase of the use.
- Fast cut in/out is possible by use of 200 degree rotation volume control.
- DCR-1200 provides parallel output of individual frequency (3 band) and mix output for professional and semi-professional use.

IMPORTANT

To prevent electric shock, do not remove the cover. No user serviceable parts are inside. Please refer servicing to a VESTAX Authorized Service Center. Always disconnect all equipment from the main supply when disconnecting or reconnecting signal leads. The power cord should be connected last. Make sure that the power switch is off when connecting. Disconnect from AC supply when equipment is not used for extended amount of time.

WARRANTY

The warranty might vary from country to country. Each distributor has their own warranty system in accordance with the country or state regulations or laws. VESTAX observes the manufacturing country's regulations.

PRECAUTIONS

- *Humidity and dust
Avoid use where there is high humidity and dust which may cause damage to internal parts.
- *Temperature
Avoid use in hot, (over 35°C) and cold, (below 5°C) locations. Keep the unit away from extreme direct heat such as direct sunlight, heating radiators, or closed vehicles.
- *Power cord handling
Connecting the power cord to other cords or joining cords together can cause fire and electric shock. This is extremely dangerous.
Take precaution when handling AC plugs and connectors. Handle only the plug or connector and do not perform these operations with wet hands.
- *Keep away from liquids
Do not stand cans containing liquids on or near the equipment. If liquid enters equipment, disconnect the power cord from the power outlet immediately.

CONTROL AND FUNCTIONS

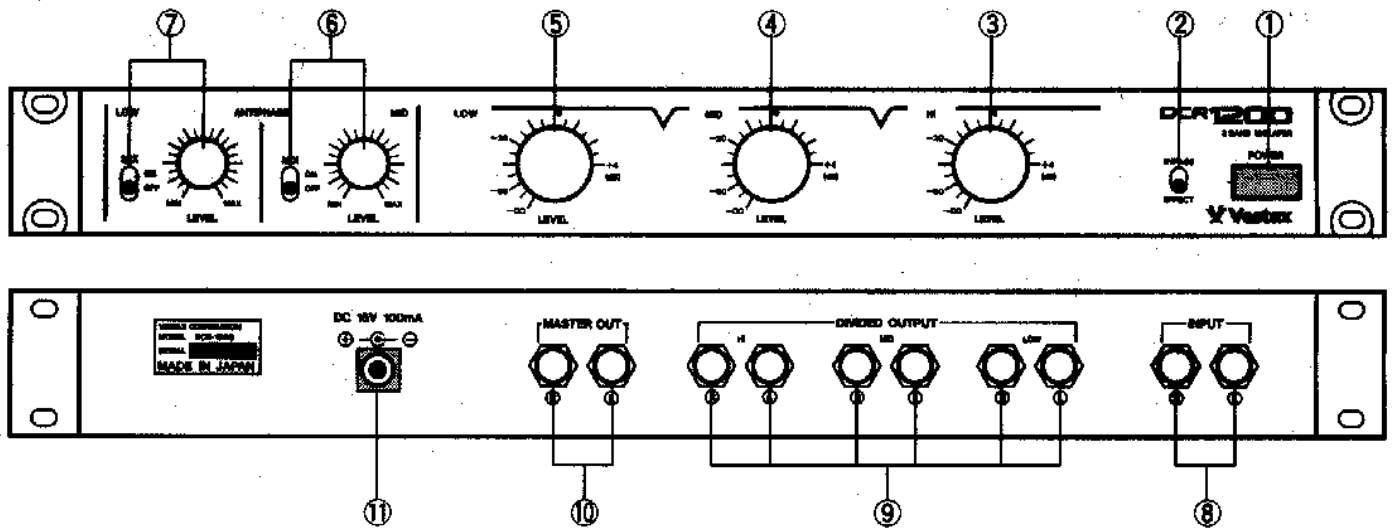

FRONT PANEL

① POWER SWITCH

ON/OFF Power switch. Please make sure the power of amplifier is OFF when you press this switch.

② BYPASS/EFFECT SWITCH

When set to the BYPASS mode, a full range signal is output regardless of the position of any controls.

③ HI VOLUME

Allows boost and cut of the treble range. Sound volume will increase when the knob is turned clockwise. When set at 12 o'clock position the output volume is the same as when in BYPASS mode. Is used to emphasize the sound of the cymbals or high hats for example.

④ MID VOLUME

Allows boost and cut of the middle range. Sound volume will increase when the knob is turned clockwise. When set at 12 o'clock position the output volume is the same as when in BYPASS mode. Can be used to cut vocal and melody from the source.

⑤ LOW VOLUME

Allows boost and cut of the bass range. Sound volume will increase when the knob is turned clockwise. When set at 12 o'clock position the output volume is the same as when in BYPASS mode. Can be used to create the effects of an acapella.

⑥ ERASE MID/MIX SWITCH

When this knob is turned clockwise the anti-phased signal of the mid frequency is mixed. The center positioned sound will be erased. e.g. When turned fully clockwise vocal sound, which are output from the center, will change to a reverb sound.

⑦ ERASE LOW/MIX SWITCH

When this knob is turned clockwise the anti-phased signal of the low frequency is mixed. The center positioned sound will be erased. e.g. When turned fully clockwise bass drum sounds, which are output from the center, will change to a reverb sound.

REAR PANEL

⑧ INPUT L/R (PHONE JACK)

Connect with the output of mixers.

⑨ DIVIDED OUTPUT

Connect to the input of amplifiers.

LOW : When connecting with the amplifiers, the signal designated by LOW VOLUME (5) function is output.

MID : When connecting with the amplifiers, the signal designated by MID VOLUME (4) function is output.

HI : When connecting with the amplifiers, the signal designated by HI VOLUME (3) function.

⑩ MASTER OUT L/R

Connect to the input of full range amplifier.

⑪ DC IN

Connects to the DC-15 AC ADAPTOR.

CONNECTION

A) CONNECT WITH RANGED SREAKERS

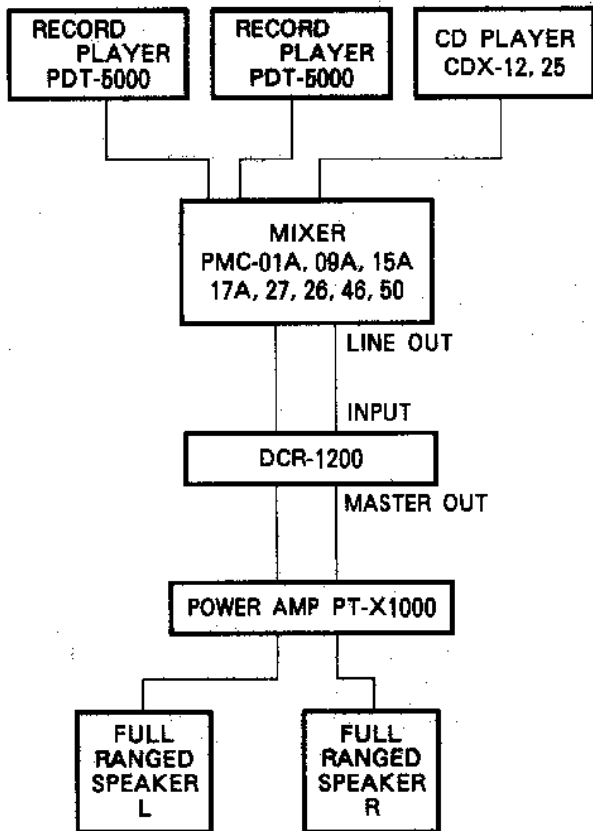

B) CONNECT WITH THREE SPEAKERS FOR EACH (LOW, MIDDLE, HI) RANGED SEPARATELY

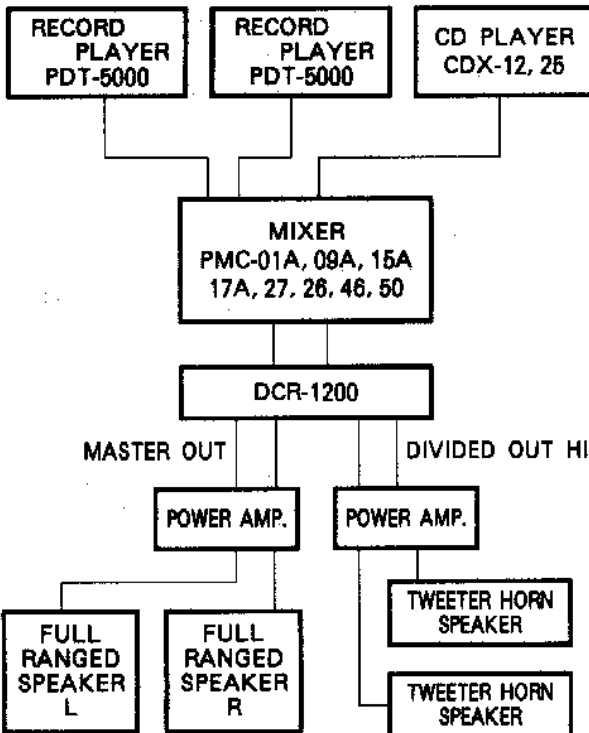
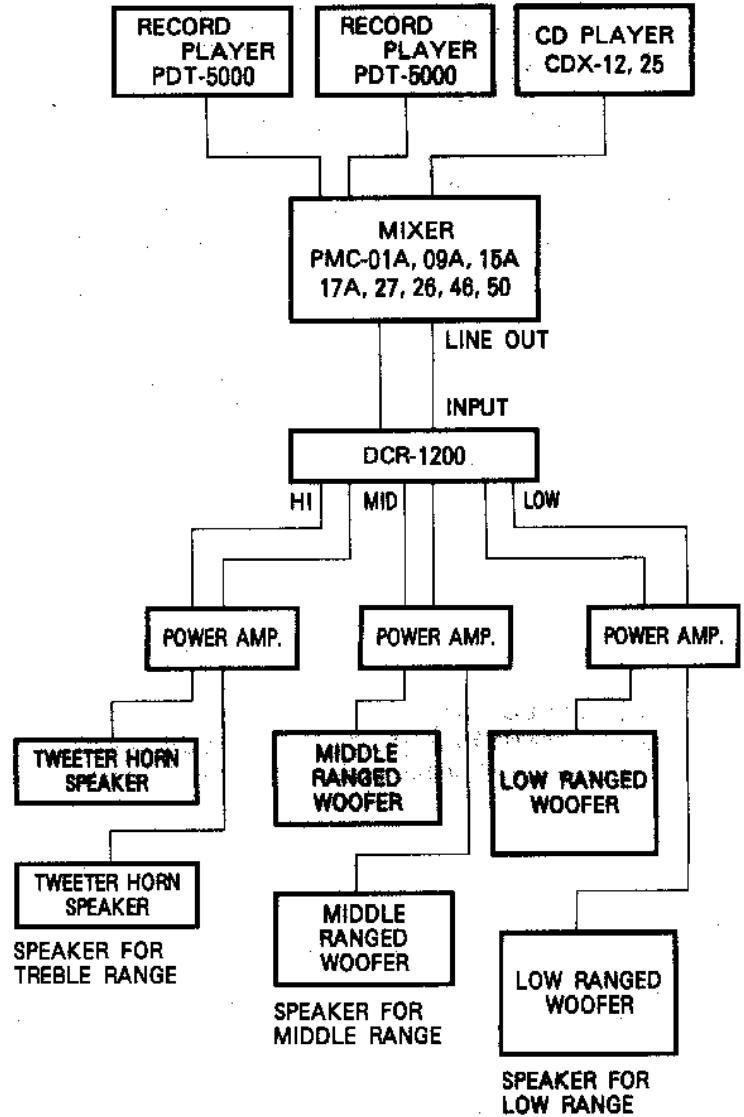

SPECIFICATIONS

INPUT LEVEL/IMPEDANCE	: -10dBV(NOM) +14dBm(MAX) 47Kohm
MASTER OUT LEVEL/IMPEDANCE	: -10dBV(NOM) +14dBm(MAX) 100ohm
GAIN MAX	: +4dB ±1dB
SLOPE	: -24dB/oct
ANTI-PHASE MIX	: +25dB
S/N	: OVER +90dB
CROSSTALK	: BELOW -65dB
POWER	: AC ADAPTOR DC-15



Vestax Corporation 1-18-6 Wakabayashi, Setagaya-ku, Tokyo 154-0023 Japan
Telephone : 81-(0)3-3412-7011 Fax : 81-(0)3-3412-7013. www.vestax.jp

***This is to certify that the product subsequently referred to
was designed and manufactured in conformity with the
following EC directives;
89/336/EEC (EMC)
73/23/EEC (LVD)***

Model type : Professional DJ Effector

Model Description : 19" Rack Mountable / DJ Effector series

Model Number : DCR-1200

Applicable Standards : EN55013:1990+A12:1994+A13:1996 Limits and methods of measurement of radio disturbance characteristics of broadcast receivers and associated equipment (including amendments A12:1994 and A13:1996) (CISPR13:1975/Amdt1:1983, modified)
EN50082-1:1997 Electromagnetic compatibility-Generic immunity standard Part1:Residential, commercial and light industry

Date : Wednesday, December 19, 2001

Place of Issue : Vestax Corporation, 1-18-6 Wakabayashi, Setagaya-ku,
Tokyo 154-0023 Japan

**Manufacturers Authorized
Signature :**

Function of Signatory :

Masaaki Shiomi

Director